







Mast - Reactions

6.6 ft - P 63A										
Height (ft)	98	115	131	148	164	180	197	213	230	246
Height (ft)	223.8	223.8	223.8	218.5	218.5	218.5	218.5	218.5	212.9	212.9
Height/P <sub>r</sub> (ft)	223.8	223.8	223.8	218.5	218.5	218.5	218.5	218.5	212.9	212.9
Ladder	10.9 ft	2	2	2	0	0	0	0	1	1
	16.4 ft	10	10	10	11	11	11	11	10	10
	32.8 ft	1	1	1	1	1	1	1	1	1
F2 (USt)	● 219	226	227	220	223	220	220	221	224	222
	■ 287	293	293	273	281	283	287	294	288	296
F3 (USt)	● 155	159	159	152	154	151	151	151	154	152
	■ 230	233	232	212	219	220	224	231	225	232

6.6 ft - V 60A - 										
Height (ft)	98	115	131	148	164	180	197	213	230	246
Height (ft)	216.2	216.2	216.2	210.6	210.6	210.6	210.6	199.8	199.8	199.8
Height/P <sub>r</sub> (ft)	216.2	216.2	216.2	210.6	210.6	210.6	210.6	199.8	199.8	199.8
Ladder	10.9 ft	0	0	0	1	1	1	0	0	0
	16.4 ft	12	12	12	11	11	11	11	11	11
F1 (USt)	● 123	125	126	120	121	120	119	119	120	120
	■ 130	132	132	123	126	126	129	121	125	129

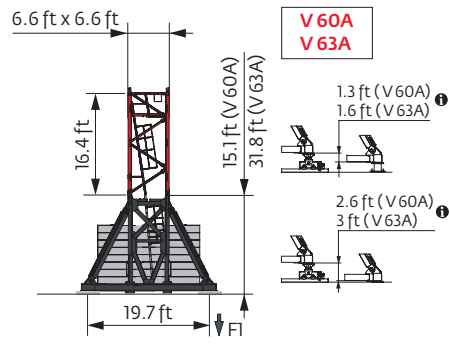
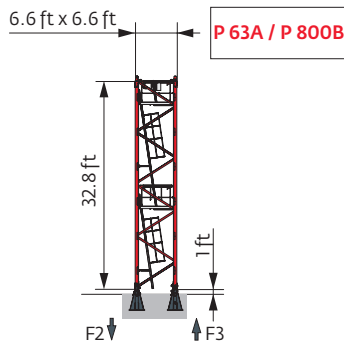
6.6 ft - V 63A - 										
Height (ft)	98	115	131	148	164	180	197	213	230	246
Height (ft)	227	227	227	221.8	221.8	221.8	221.8	216.2	216.2	216.2
Height/P <sub>r</sub> (ft)	227	227	227	221.8	221.8	221.8	221.8	216.2	216.2	216.2
Ladder	10.9 ft	1	1	1	2	2	2	0	0	0
	16.4 ft	11	11	11	10	10	10	11	11	11
F1 (USt)	● 130	133	133	127	128	127	127	128	130	129
	■ 149	151	151	140	145	146	148	144	150	155



6.6 ft - ZX 640 - 										
W (ft)	98	115	131	148	164	180	197	213	230	246
$\bar{r}$ (ft)	221.5	221.5	221.5	216.2	221.5	216.2	216.2	221.5	210.6	216.2
$\bar{r}/P^*$ (ft)	221.5	221.5	221.5	216.2	221.5	216.2	216.2	221.5	210.6	216.2
	10.9 ft	0	0	1	0	1	1	0	2	1
	16.4 ft	11	11	11	10	11	10	11	9	10
	32.8 ft	1	1	1	1	1	1	1	1	1
FI (Ust)	● 128	131	132	130	133	128	127	133	132	133
	■ 138	140	140	135	142	135	138	150	140	151

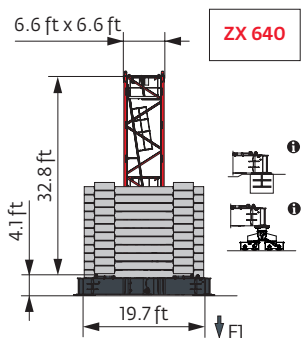

Note: When "ASCE" is noted in this data sheet it is referring to 115 mph Wind Zone, Exposure B, Design Wind Speed = 98 mph. See back cover for design wind speed calculations.

**i** Motorized accesses: adapted mast compositions, base ballast and reactions.

Other mast compositions - Please consult us

Anchorage

**i**

Base ballast

**(USt) / 6.6 ft - V 60A -**

Δ (ft)	98	115	131	148	164	180	197	213	230	246
216.2	132.3	132.3	132.3							
210.6	132.3	119.1	119.1	119.1	119.1	119.1	119.1			
199.8	119.1	119.1	105.8	105.8	105.8	105.8	105.8	119.1	119.1	119.1
183.4	105.8	92.6	92.6	92.6	92.6	92.6	92.6	92.6	92.6	92.6
167	79.4	79.4	79.4	79.4	79.4	79.4	66.1	79.4	79.4	79.4
150.6	66.1	66.1	66.1	66.1	66.1	52.9	52.9	66.1	66.1	66.1
134.2	66.1	66.1	66.1	52.9	52.9	52.9	52.9	52.9	52.9	66.1
117.8	66.1	66.1	66.1	52.9	52.9	52.9	52.9	52.9	52.9	66.1
101.4	66.1	66.1	66.1	52.9	52.9	52.9	52.9	52.9	52.9	66.1
85	66.1	66.1	66.1	52.9	52.9	52.9	52.9	52.9	52.9	66.1
68.6	66.1	66.1	66.1	52.9	52.9	52.9	52.9	52.9	52.9	66.1

**(USt) / 6.6 ft - V 63A -**

Δ (ft)	98	115	131	148	164	180	197	213	230	246
227	145.5	145.5	145.5							
221.8	145.5	132.3	132.3	132.3	132.3	132.3	132.3			
216.2	132.3	132.3	132.3	132.3	132.3	119.1	119.1	132.3	132.3	132.3
199.8	119.1	119.1	119.1	105.8	105.8	105.8	105.8	119.1	119.1	119.1
183.4	105.8	92.6	92.6	92.6	92.6	92.6	92.6	105.8	92.6	92.6
167	92.6	79.4	79.4	79.4	79.4	79.4	79.4	79.4	79.4	79.4
150.6	66.1	66.1	66.1	66.1	66.1	66.1	52.9	66.1	66.1	66.1
134.2	66.1	66.1	66.1	52.9	52.9	52.9	52.9	52.9	66.1	66.1
117.8	66.1	66.1	66.1	52.9	52.9	52.9	52.9	39.7	52.9	66.1
101.4	66.1	66.1	66.1	52.9	52.9	52.9	52.9	39.7	52.9	66.1
85	66.1	66.1	66.1	52.9	52.9	52.9	52.9	39.7	39.7	66.1
68.6	66.1	66.1	66.1	52.9	52.9	52.9	52.9	39.7	39.7	66.1

**(USt) / 6.6 ft - ZX 640 -**

Δ (ft)	98	115	131	148	164	180	197	213	230	246
221.5	143.3	143.3	143.3		143.3			143.3		
216.2	143.3	143.3	132.3	143.3	143.3	132.3	132.3	132.3		143.3
210.6	132.3	132.3	132.3	132.3	132.3	132.3	132.3	132.3	143.3	143.3
194.2	110.2	110.2	110.2	110.2	110.2	110.2	110.2	110.2	121.3	121.3
177.8	99.2	99.2	99.2	99.2	88.2	88.2	88.2	88.2	99.2	99.2
161.4	77.2	88.2	88.2	77.2	77.2	77.2	77.2	66.1	77.2	77.2
145	66.1	77.2	77.2	66.1	66.1	55.1	55.1	55.1	55.1	55.1
128.6	55.1	66.1	66.1	55.1	55.1	44.1	44.1	44.1	44.1	55.1
112.2	55.1	66.1	66.1	55.1	55.1	44.1	44.1	44.1	44.1	55.1
95.8	55.1	66.1	66.1	55.1	55.1	44.1	44.1	44.1	44.1	55.1
79.4	55.1	66.1	66.1	55.1	55.1	44.1	44.1	44.1	44.1	55.1
63	55.1	66.1	66.1	55.1	55.1	44.1	44.1	44.1	44.1	55.1

Load curves



▼▲▲▲▲▲ (ft)		72	89	98	105	115	121	131	138	148	154	164	171	180	187	197	203	213	220	230	236	246	ft	
▼▲▲▲▲▲	13.2 USt	▼▲▲▲▲▲											▼▲▲▲▲▲											
▼▲▲▲▲▲	6.6 USt	▼▲▲▲▲▲											▼▲▲▲▲▲											
246	10.2 → 73.6 10.2 → 75.4	130.7 - 142 134 - 145.5	13.2	10.6	9.4	8.7	7.8	7.3	6.6	6.6	6.3	6	5.6	5.3	5	4.8	4.4	4.2	4	3.8	3.5	3.4	3.2	USt
230	10.2 → 78.8 10.2 → 83.9	140.1 - 151.7 149.3 - 161.7	13.2	11.5	10.2	9.4	8.4	7.9	7.2	6.8	6.6	6.5	6	5.7	5.3	5.1	4.8	4.5	4.3	4.1	3.8	3.7	3.5	USt P+
213	10.2 → 83.2 10.2 → 88	149.3 - 161.3 157.9 - 170.6	13.2	12.3	10.9	10.1	9.1	8.5	7.7	7.3	6.7	6.6	6.5	6.2	5.8	5.6	5.3	5.1	4.8	4.6	4.4	4.6	USt	
197	10.2 → 87.9 10.2 → 92.3	158.6 - 170.8 166.6 - 180.4	13.2	13.1	11.6	10.8	9.7	9.1	8.3	7.8	7.2	6.8	6.6	6.6	6.2	6	5.6	5.6	5.3	5	4.9	4.6	USt P+	
180	10.2 → 90.1 10.2 → 95.5	162.6 - 175.2 172.4 - 180.4	13.2	13.2	12	11.1	10	9.4	8.6	8.1	7.4	7.1	6.6	6.6	6.4	6.6	6.5	6.2	5.7	5.5	5.1	4.9	USt P+	
164	10.2 → 94.3 10.2 → 98.7		13.2	13.2	12.6	11.7	10.6	9.9	9.1	8.6	7.9	7.5	7	6.6	6.5	6.2	5.7	5.5	5.1	4.9	4.6	USt		
148	10.2 → 96.6 10.2 → 101		13.2	13.2	13.2	12.7	11.4	10.7	9.8	9.3	8.5	8.1	7.3	6.6	6.6	6.2	5.7	5.5	5.1	4.9	4.6	USt P+		
131	10.2 → 97.6 10.2 → 102.5		13.2	13.2	13.1	12.2	11	10.3	9.4	8.8	8.1	7.3	6.6	6.6	6.2	5.7	5.5	5.1	4.9	4.6	USt P+			
115	10.2 → 97.2 10.2 → 101.6		13.2	13.2	13	12.1	11	10.3	9.4	8.8	8.1	7.3	6.6	6.6	6.2	5.7	5.5	5.1	4.9	4.6	USt P+			
98	10.2 → 98 10.2 → 98		13.2	13.2	13.2	12.7	11.5	10.3	9.4	8.8	8.1	7.3	6.6	6.6	6.2	5.7	5.5	5.1	4.9	4.6	USt P+			

$$W_{jib} = W_{counter-jib} - 0.67 \text{ USt max.}$$



▼▲▲▲▲▲ (ft)		72	89	98	105	115	121	131	138	148	154	164	171	180	187	197	203	213	220	230	236	246	ft	
▼▲▲▲▲▲	13.2 USt	▼▲▲▲▲▲											▼▲▲▲▲▲											
▼▲▲▲▲▲	6.6 USt	▼▲▲▲▲▲											▼▲▲▲▲▲											
246	7.9 → 73.9 7.9 → 75.7	131.8 - 134.7 135.1 - 138.1	13.2	10.7	9.4	8.7	7.8	7.3	6.6	6.4	5.9	5.6	5.2	4.9	4.6	4.3	4	3.8	3.5	3.4	3.1	2.95	2.75	USt
230	7.9 → 78.8 7.9 → 83.9	141 - 144.4 150.3 - 154.2	13.2	11.6	10.2	9.5	8.5	8	7.2	6.8	6.4	6.1	5.6	5.4	4.9	4.7	4.4	4.2	3.9	3.7	3.4	3.3	3.1	USt P+
213	7.9 → 83.6 7.9 → 88.6	150.4 - 154.2 159.1 - 162.8	13.2	12.4	11	10.2	9.2	8.6	7.8	7.4	6.8	6.6	6.1	5.8	5.4	5.1	4.7	4.5	4.2	4	3.8	3.5	3.4	USt P+
197	7.9 → 88.6 7.9 → 92.7	159.9 - 164 168 - 171.9	13.2	13.2	11.7	10.9	9.8	9.2	8.4	7.9	7.3	6.9	6.6	6.3	5.9	5.6	5.3	5	4.6	4.4	4.2	4	USt P+	
180	7.9 → 90.5 7.9 → 95.9	163.9 - 167.8 173.8 - 177.9	13.2	13.2	12	11.2	10.1	9.5	8.6	8.1	7.5	7.1	6.6	6.5	6.1	5.8	5.4	5.1	4.7	4.4	4.2	4	USt	
164	7.9 → 94.7 7.9 → 99.2		13.2	13.2	12.7	11.8	10.7	10	9.2	8.7	8	7.6	7.1	6.8	6.5	6.2	5.8	5.4	5.1	4.7	4.4	4.2	USt P+	
148	7.9 → 97 7.9 → 101.7		13.2	13.2	13	12.1	10.9	10.2	9.4	8.8	8.2	7.6	7.1	6.8	6.5	6.2	5.8	5.4	5.1	4.7	4.4	4.2	USt P+	
131	7.9 → 98.4 7.9 → 102.9		13.2	13.2	13.2	12.2	11.1	10.4	9.5	9.3	8.6	8	7.6	7.1	6.8	6.5	6.2	5.8	5.4	5.1	4.7	4.4	USt P+	
115	7.9 → 97.7 7.9 → 102.1		13.2	13.2	13.1	12.2	11	10.3	9.4	8.8	8.1	7.3	6.6	6.6	6.2	5.7	5.5	5.1	4.9	4.6	USt P+			
98	7.9 → 98.4 7.9 → 98.4		13.2	13.2	13.2	12.8	11.6	10.3	9.4	8.8	8.1	7.3	6.6	6.6	6.2	5.7	5.5	5.1	4.9	4.6	USt P+			

$$W_{jib} = W_{counter-jib} - 0.19 \text{ USt max.}$$

Jib weight & counter-jib ballast

▼▲▲▲▲▲	▼▲▲▲▲▲ (lb) (+/- 5%)			▼▲▲▲▲▲			▼▲▲▲▲▲		
	▼▲▲▲▲▲	▼▲▲▲▲▲	▼▲▲▲▲▲	10,141 lb	3,373 lb	▼▲▲▲▲▲ (lb)	6,768 lb	3,373 lb	▼▲▲▲▲▲ (lb)
246 ft	39,840	38,964	39,996	5	2	57,452	8	1	57,519
230 ft	39,253	38,411	39,388	5	2	57,452	8	1	57,519
213 ft	38,402	37,626	38,603	5	2	57,452	8	1	57,519
197 ft	36,363	35,653	36,520	5	1	54,079	8	0	54,146
180 ft	36,387	35,677	36,544	5	1	54,079	8	0	54,146
164 ft	34,595	33,885	34,751	5	2	57,452	8	1	57,519
148 ft	34,013	33,303	34,169	5	2	57,452	8	1	57,519
131 ft	32,221	31,511	32,377	5	0	50,706	7	1	50,750
115 ft	31,052	30,342	31,209	4	2	47,311	7	0	47,377
98 ft	29,205	28,495	29,361	4	1	43,938	6	1	43,982

CBS - 10,141 lb

CBU - 6,768 lb

CBY - 3,373 lb

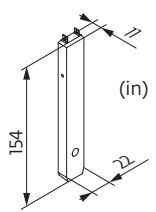
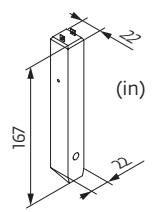
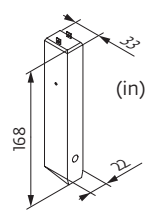





Dimensions and weight

Slewing crane part:  246 ft -  -  -  90 HPL™

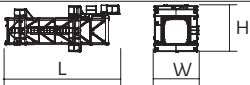
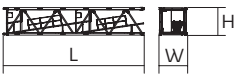
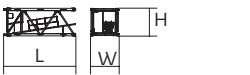
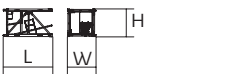
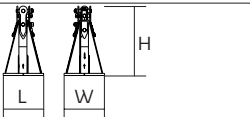

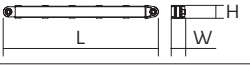
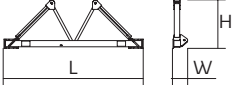
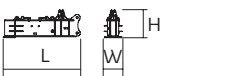
Slewing crane part		L (ft)	W (ft)	H (ft)	lb (+/- 5%)	
Counter-jib		Ⓐ	39.4	4.1	8.2	31,107
		Ⓑ	39.4	4.1	8.2	29,983
		Ⓒ	39.4	4.1	8.2	25,441
Cab mast + cab		Ultra View	16.5	7.3	8.2	14,815
Towerhead		⊔ 6.6 ft	9.7	8.1	8.2	16,799
Hoisting winch (+ rope)		90 HPL™	14	7.5	7.6	9,921
Jib section		① 6 DVF	35.3	5.9	9	12,015
Jib section		②	33.5	3.9	8.2	6,934
		③	33.8	3.9	7.9	5,335
		⑤	33.5	3.9	7.8	3,439
		⑥	33.6	3.9	6.9	2,723
		⑦	33.4	3.9	6	2,094
Jib section		④	17.3	3.9	7.8	2,116
		⑧	16.7	3.9	5	683
		⑨	16.7	3.9	4.6	485
Trolley		 13.2 USt	6.1	5	3.4	882
Pulley block		 13.2 USt	3.9	1.4	7.6	1,003
Trolley		 13.2 USt	5.2	5	3.2	463
Trolley		 13.2 USt	5.6	5	3.4	540
		 6.6 USt	6.1	5	3.2	520
Pulley block		 13.2 USt	5.4	0.7	5.8	992
		 6.6 USt	3.6	0.9	5.3	584

Crane tower		L (ft)	W (ft)	H (ft)	lb (+/- 5%)	
Telescopic cage T 61		6.6 ft	35.5	13.6	14.7	21,385
K 649B KM 649E KRM 6410B		6.6 ft	33.6 33.8 33.6	6.8 6.7 6.9	6.7 6.7 6.8	11,663 10,692 15,653
K 649A KMT 649A KR 649A KRMT 649A		6.6 ft	17.2 17.2 17.2 17.2	6.8 6.8 6.9 6.9	6.7 6.7 6.8 6.8	6,184 5,666 7,165 6,724
K 649C KMT 649C KRMT 649C		6.6 ft	11.7 11.7 11.7	6.8 6.8 6.9	6.7 6.7 6.8	4,376 4,542 5,401
Fixing angles		P 63A / P 800B	2.5	2.5	4.2	1,025
Basic mast unit		V 60A V 63A	16.4 32.9	7.9 7.9	7.9 7.9	10,494 16,887
Struts		V 60A V 63A	14.8 14.8	1 1.1	1 1.1	1,036 1,235
Half-bearer		V 60A V 63A	22 22	2.3 2.3	7.6 7.6	4,057 4,101
1/2 Cross girder		ZX 640	14.3	3.3	5.1	7,319
Cross girder		ZX 640	30	3.9	5.1	15,168

Mechanisms

480 V - 60 Hz													hp	kW	
	<b>90 HPL™ 30</b>	fpm USt	176 6.6	228 5	326 3.3	469 1.7	723 0.2	90 13.2	120 9.9	172 6.6	244 3.3	361 0.9	90	66	2,772 ft
	<b>6 DVF 6 Optima</b>	fpm	0 → 138 (13.2 USt) 0 → 276 (8.8 USt) 0 → 328 (4.4 USt)									5.5	4		
	<b>RVF 172 Optima+</b>	rpm	0 → 0.9									2 x 10	2 x 7.5		

	<b>kVA</b>		
480 V (+6% -10%) 60 Hz	90 HPL™: 96 → 60 kVA		

These mast combinations meet the EN 14439 and ASME B30.3-2016 specifications for "out of service" wind conditions, provided the illustrated wind speed matches required design wind speed for the location of the tower crane. The "out of service" design wind speed was determined in accordance with ASCE 7-10, Figure 26.5-1A. The wind velocity, used for this configuration was 98 mph (158 kph), which represents a nominal design 3-second wind gust at 33 ft (10 m) above ground for Exposure B category. A factor of 0.85 was applied to the 700-year ultimate design wind speed of 115 mph (185 kph), per ASCE 37-02, with the assumption that this crane is considered a temporary structure used during a construction period of 2 years or less.

- Jib elevation
- Standard equipment
- Options
- Potain Plus function: Plus load curves
- Hook heights with Plus load curves
- Reactions in service
- Reactions out of service
- Total ballast weight
- Jib weight
- Lorry 44 ft
- Container High Cube 40 ft, and/or Flat Rack 20 ft
- Hoisting
- Trolleying
- Slewing
- Travelling
- Required power
- Power Control Function: winch speeds adapted to the available power
- Consult us

This commercial document is not legally binding. For any technical information, please refer to the corresponding instructions.

