

Series 1800: National Telescoping Crane

America's Leading Manufacturer of Truck-Mounted Hydraulic Cranes.

1800



Photos may show optional equipment.

Why Buy a National Series 1800?



- **40-ton Rating** – The 1800 is a 40-ton machine, an 11% increase in capacity over the Series 1500.
- **New 142-foot Five-section Boom** – The longest in its size range. The long boom allows the operator to perform more lifts without the use of a jib, reducing setup time and improving efficiency. Also available are optional boom lengths of 79', 103' and 127'.
- **Overload Protection** – All National cranes are equipped with overload protection:
 - Load Moment Indicator (LMI) standard on all Series 1800 machines.
 - LMI display and CPU are weatherproof.
 - LCD display is visible in full or low light.
 - All crane load lifting values are displayed simultaneously.
- **Self-lubricating “Easy glide” Boom Wear Pads/Polymer Paint** – The standard self-lubricating boom pads, used in conjunction with National's specially formulated *Polymer Paint*[®], reduce the conditions that cause boom chatter and vibration. The net result is smoother crane operation. [†] *Patent pending*
- **Deluxe Operator's Cab** – Rigid galvanized steel structure, well-insulated, with ample safety glass for operator visibility and comfort. Multi-position seat with folding back and armrests housing either two single-axis hydraulic controllers or one dual-axis joystick in each arm rest. Available with optional A/C.
- **Outriggers** – Outrigger span of 24'8” when full; 17'6” at mid-span.
 - Ground-level outrigger controls on both sides.
 - In-cab outrigger controls for all functions.
 - Front bumper stabilizer for stable base over front.
- **Adjustable Swing Speed** – Standard on the 1800. A control knob located on the swing motor brake release valve can be easily adjusted to the crane operator's swing speed preference.
- **Heavier Duty Torsion Box** – The stronger standard torsion box improves rigidity, reduces truck frame flex and reduces the need for counterweight.
- **Tailswing Counterweight** – Provides stability through 360° operation.
- **Speedy Reeve Boom Tip and Sheave Blocks** – These standard features simplify rigging changes.
 - One-three part line block is standard.
- **Pre-painted Components** – Painting crane components before assembly reduces the possibility of rust, improves serviceability and enhances the appearance of the machine.
- **Oil Cooler** – Standard oil cooler with electric fan mounted at boom rest.
- **Improved Serviceability** – Bearings on the boom extend and retract cables can be greased through access holes in the boom side plates.
- **Hydraulic System** – Pressure-compensated control valves with load-sensing variable displacement piston pump.
- **New State-of-the-Art Control Valve** – Provides smoother operation. The new design eliminates parts, reducing repair costs and improving the machine's serviceability.
- **National Crane Is the Market Leader** – National is number one in the production of commercial truck-mounted boom trucks.
- **National has the Boom Truck Industry's Leading Test Program** – Every structural part of the crane is cycle tested, some up to 60,000 cycles at full capacity. In addition to cycle testing, each model is subjected to state-of-the-art strain gage testing that measures metal deformation as small as one one-millionth of an inch. The net result is that weak areas are caught in test, not on job sites where costly downtime occurs.
- **Parts Are Available** for all National Crane machines, even if they are 35 years old.
- **National has a formalized quality program** and is ISO 9001 approved.

• 40-ton (36.29-t)
maximum capacity

• 190-ft (57.91-m) maximum
vertical reach*

• 149-ft (45.42-m) maximum
vertical hydraulic reach*

• Load Moment
Indicator system (LMI)

• Proportional boom
extension

• High performance
planetary winch

• Vickers PVH 131 pressure
compensated, load sensing, axial
piston, variable volume pump
direct mounts to PTO.

* Maximum vertical reach is
ground-level to boom tip height
at maximum
extension and angle with
outriggers/stabilizers
fully extended.

National Crane is a Quality Product That Will Provide Years of Service.

1800 Capacities

Load Rating Chart: Model 18142 with 26-ft jib

Series 1800 Load Rating Charts are available for all Model 1800 cranes. National will send you a chart by FAX or mail on request – or you may secure needed load rating information through your nearest National dealer.

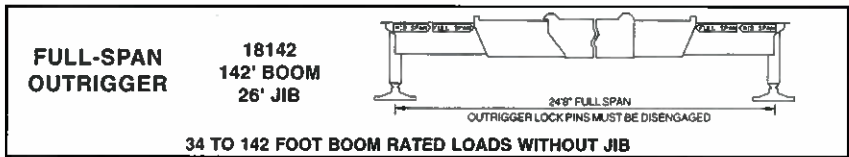
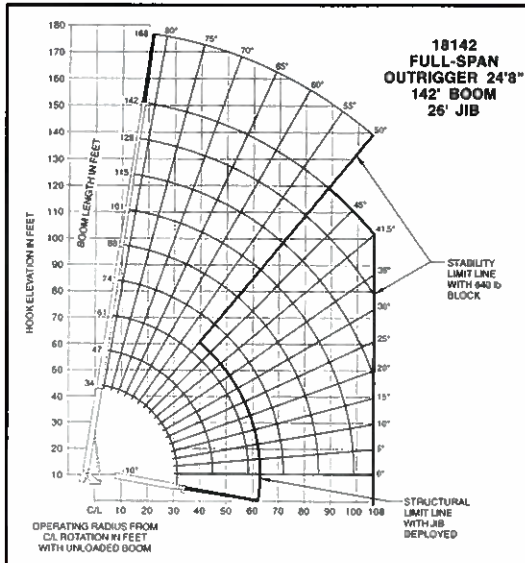

34 TO 142 FOOT BOOM RATED LOADS WITHOUT JIB											
34 FT BOOM			47 FT BOOM			61 FT BOOM			74 FT BOOM		
Rad.	Angle	Capacity	Rad.	Angle	Capacity	Rad.	Angle	Capacity	Rad.	Angle	Capacity
7	76.3	80,000									
8	74.3	74,000									
10	70.5	63,000	10	76.6	40,000						
12	66.7	55,000	12	74.2	40,000	12	78.7	40,000			
15	60.6	43,000	15	70.5	40,000	15	75.8	38,000	15	79.2	32,000
20	49.6	29,700	20	63.6	30,600	20	70.8	30,000	20	75.2	26,600
25	36.4	22,000	25	56.2	22,800	25	65.4	23,000	25	71.0	21,500
30	16.2	17,000	30	48.1	17,700	30	59.8	17,900	30	66.6	17,400
35	0	15,800	35	38.9	14,100	35	53.8	14,300	35	62.1	14,400
40			40	27.1	11,400	40	47.4	11,800	40	57.4	11,800
45			45	10.9	9,400	45	40.9	9,700	45	52.9	9,900
50						50	32.6	8,000	50	47.6	8,200
55						55	21.5	6,800	55	41.7	6,900
60							0	5,900	60	35.1	5,700
65									65	27.1	4,850
70									70	15.4	4,000
75										0	3,800

88 FT BOOM												101 FT BOOM			115 FT BOOM			128 FT BOOM			142 FT BOOM		
Rad.	Angle	Capacity	Rad.	Angle	Capacity	Rad.	Angle	Capacity	Rad.	Angle	Capacity	Rad.	Angle	Capacity	Rad.	Angle	Capacity	Rad.	Angle	Capacity			
20	78.2	23,000	20	79.9	17,000																		
25	74.9	20,000	25	77.2	15,800	25	79.1	13,000															
30	71.3	17,000	30	74.4	14,200	30	76.7	11,900	30	78.5	9,500	30	79.7	8,000									
35	67.7	14,600	35	71.5	12,700	35	74.2	10,900	35	76.5	9,000	35	77.8	7,500									
40	63.8	11,900	40	68.3	10,800	40	71.9	9,800	40	74.4	8,500	40	75.9	7,000									
45	60.3	10,000	45	65.4	9,500	45	69.3	9,000	45	72.1	7,800	45	73.9	6,400									
50	56.2	8,300	50	62.1	8,200	50	66.5	8,000	50	69.6	7,000	50	71.8	5,800									
55	51.9	7,000	55	58.6	7,000	55	63.6	7,100	55	67.1	6,200	55	69.5	5,200									
60	47.3	5,800	60	54.9	5,800	60	60.5	5,900	60	64.4	5,300	60	67.3	4,700									
65	42.3	4,900	65	51.1	4,950	65	57.3	5,000	65	61.7	4,600	65	65.0	4,200									
70	36.8	4,100	70	47.1	4,150	70	54.0	4,200	70	59.0	4,000	70	62.7	3,750									
75	30.5	3,400	75	42.7	3,450	75	50.5	3,500	75	56.2	3,400	75	60.2	3,300									
80	22.5	2,800	80	38.1	2,850	80	46.9	2,900	80	53.2	2,900	80	57.8	2,950									
85	8.6	2,300	85	32.8	2,300	85	43.1	2,350	85	50.0	2,350	85	55.1	2,400									
90	0	2,200	90	26.5	1,850	90	39.0	1,900	90	46.8	1,900	90	52.3	1,950									
95			95	18.3	1,450	95	34.4	1,500	95	43.3	1,500	95	49.4	1,500									
100				0	1,100	100	29.3	1,100	100	39.6	1,100	100	46.5	1,150									
105						105	23.0	750	105	35.7	800	105	43.4	800									
108						108	18.3	650	108	33.1	650	108	41.5	650									

NOTE:
 1. All capacities are in pounds, angles in degrees, radius in feet.
 2. Loaded boom angles are given as reference only.
 3. Shaded areas are structurally limited capacities.

Caution:

- Do not operate crane booms, jib extensions, any accessories or loads within 10 ft (3m) of live power lines or other conductors of electricity
- Jib and boom capacities shown are maximum for each section
- Do not exceed capacities at reduced radii
- Load ratings shown on the load rating charts are maximum allowable loads with the outriggers properly extended on a firm, level surface and the crane leveled and mounted on a factory-recommended truck
- Always level the crane with the level indicator located on the crane
- The operator must reduce loads to allow for factors such as wind, ground conditions, operating speeds and their effects on freely suspended loads
- Overloading this crane may cause structural collapse or instability
- Weights of any accessories attached to the boom or loadline must be deducted from the load chart capacities
- Do not exceed jib capacities at any reduced boom lengths
- Do not deadhead lineblock against boom tip when extending boom or winching up
- Keep at least three wraps of loadline on drum at all times
- Use only specified cable with this machine

RATED LOAD REDUCTIONS WITH JIB				26 FT JIB RATED LOADS			
BOOM LENGTH	26 FT JIB STOWED		26 FT JIB ERECTED		Radius Fully Extended	Loaded Boom Angle	Rated Loads All Boom Lengths
	Reduce load	Capacity	Reduce load	Capacity			
34'	Reduce load	525 lb.	Reduce load	1,050 lb.	33	80	4,000
47'	Reduce load	400 lb.	Reduce load	1,000 lb.	50	75	3,800
61'	Reduce load	300 lb.	Reduce load	950 lb.	65	70	3,200
74'	Reduce load	250 lb.	Reduce load	925 lb.	78	65	2,450
88'	Reduce load	200 lb.	Reduce load	900 lb.	90	60	1,800
101'	Reduce load	200 lb.	Reduce load	900 lb.	101	55	1,250
115'	Reduce load	150 lb.	Reduce load	875 lb.	112	50	650
126'	Reduce load	150 lb.	Reduce load	875 lb.			
142'	Reduce load	125 lb.	Reduce load	850 lb.			

Mounting Configurations

The configurations are based on the Series 1800 with an 85% stability factor. The complete unit must be installed in accordance with factory requirements and a test performed to determine actual stability and counterweight requirements since individual truck chassis vary.

1800 w/Tag Axle 60,000 GVWR (79/103/127' Boom)

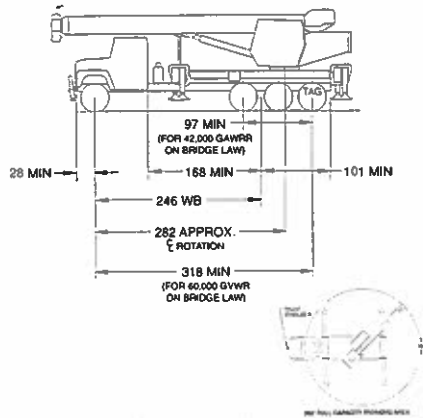

Configuration 1 – 79' - 103' - 127' Boom with Tag Axle

Working area	360°
Gross Axle Weight Rating Front	20,000 lb (9072 kg)
Gross Axle Weight Rating Rear	40,000 lb (18 144 kg)
Gross Vehicle Weight Rating	60,000 lb (27 216 kg)
Wheelbase	246 in (625 cm)
Cab to Axle/trunnion (CA/CT)	168 in (427 cm)
Frame Section Modulus (SM) Front axle to end of AF: 110,000 PSI (785 MPa)	30.0 in ³ (426 cm ³)
Stability Weight, Front	9,450 lb (4286 kg) minimum*
Stability Weight, Rear	10,800 lb (4899 kg) minimum*
Estimated Average Final Weight	56,945 lb (25 830 kg)**

This configuration shows the 360° working area that is achieved with the front stabilizer (standard on the Series 1800). The front stabilizer is essential when extending the boom and lifting loads over the front of the truck.

* Estimated axle scale weights prior to installation of crane, stabilizers and subbase for 85% stability.

** Estimated final weight (wet) with 127 ft (38.72 m) boom, 400 lb (182 kg) 3 part block, steel decks, 2,300 lb (1,045 kg) swinging counterweight, 100-gal (379-L) fuel tank and two workers in cab.

1800 w/Pusher Axle 58,000 GVWR (79/103/127' Boom)

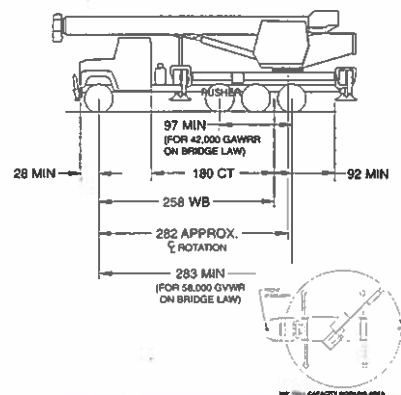

Configuration 2 – 79' - 103' - 127' Boom with Pusher Axle

Working area	360°
Gross Axle Weight Rating Front	20,000 lb (9072 kg)
Gross Axle Weight Rating Rear	40,000 lb (18 144 kg)
Gross Vehicle Weight Rating	60,000 lb (27 216 kg)
Wheelbase	258 in (655 cm)
Cab to Axle/trunnion (CA/CT)	180 in (457 cm)
Frame Section Modulus (SM) Front axle to end of AF: 110,000 PSI (785 MPa)	30.0 in ³ (426 cm ³)
Stability Weight, Front	9,975 lb (4525 kg) minimum*
Stability Weight, Rear	10,275 lb (4661 kg) minimum*
Estimated Average Final Weight	56,945 lb (25 830 kg)**

This configuration shows the 360° working area that can be achieved with the front stabilizer (standard on the Series 1800). The front stabilizer is essential when extending the boom and lifting loads over the front of the truck.

* Estimated axle scale weights prior to installation of crane, stabilizers and subbase for 85% stability.

** Estimated final weight (wet) with 127 ft (38.72 m) boom, 400 lb (182 kg) 3 part block, steel decks, 2,300 lb (1,045 kg) swinging counterweight, 100-gal (379-L) fuel tank and two workers in cab.

1800 w/Tag Axle 60,000 GVWR (142' Boom)

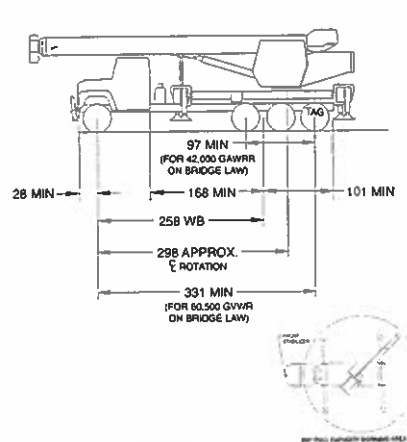

Configuration 3 – 142' Boom with Tag Axle

Working area	360°
Gross Axle Weight Rating Front	20,000 lb (9072 kg)
Gross Axle Weight Rating Rear	40,000 lb (18 144 kg)
Gross Vehicle Weight Rating	60,000 lb (27 216 kg)
Wheelbase	258 in (655 cm)
Cab to Axle/trunnion (CA/CT)	168 in (427 cm)
Frame Section Modulus (SM) Front axle to end of AF: 110,000 PSI (785 MPa)	30.0 in ³ (426 cm ³)
Stability Weight, Front	9,275 lb (4207 kg) minimum*
Stability Weight, Rear	10,575 lb (4797 kg) minimum*
Estimated Average Final Weight	58,000 lb (26 308 kg)

This configuration shows the 360° working area that can be achieved with the front stabilizer (standard on the Series 1800). The front stabilizer is essential when extending the boom and lifting loads over the front of the truck.

* Estimated axle scale weights prior to installation of crane, stabilizers and subbase for 85% stability.

** Estimated final weight (wet) with 142 ft (43.29 m) boom, 400 lb (182 kg) 3 part block, steel decks, 2,300 lb (1,045 kg) swinging counterweight, 100-gal (379-L) fuel tank and two workers in cab.

Note: A configuration is available featuring the National Series 1800 with 127' boom on a three-axle chassis. This configuration is road legal without permit in some states on state and local roads. It does not meet federal bridge law. Contact the factory for information regarding this configuration.

Notes:

- Gross Vehicle Weight Rating (GVWR) is dependent on all components of the vehicle (axles, tires, springs, frame, etc.) meeting manufacturer's recommendations; always specify GVWR when purchasing trucks
- Diesel engines require a variable speed governor and energize-to-run fuel solenoid for smooth crane operation; electronic fuel injection requires EET engine remote throttle

- All mounting data is based on a National Series 1800 with an 85 percent stability factor
- The complete unit must be installed in accordance with factory requirements, and a test performed to determine actual stability and counterweight requirements per SAE J765; contact the factory for details
- Transmission neutral safety interlock switch is required

*Estimated axle scale weights prior to installation of crane and stabilizer for 85% stability.

Boom and Jib Combinations Data

Available in four basic models: 1879 3-section, 18103 4-section, 18127 5-section, and 18142 5-section.

Model 1879 — Equipped with a 31-79 ft (9.45-24.08 m) four-section boom. There are no jib options for this boom model. Maximum tip height is 87 ft (26.52 m).

31-79 ft (9.45-24.08 m) three-section hydraulic boom



Model 18103 — Equipped with a 31-103 ft (9.45-31.40 m) four-section boom. This model can be equipped with a 31 ft (9.45 m) jib, offering a vertical reach of 142 ft (43.29 m) and a 31- 55-ft (9.45-16.76 m) side-stowing folding jib, providing a vertical reach of 166 ft (50.60 m).

31-103 ft (9.45-31.40 m) four-section hydraulic boom



31-103 ft (9.45-31.40 m) four-section hydraulic boom



18FJ31OS 31 ft (9.45 m) single-section offsettable manual jib

31-103 ft (9.45-31.40 m) four-section boom

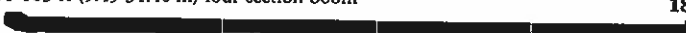

18FJ55 31-55 ft (9.45-16.76 m) two-section manual jib

Model 18127 — Equipped with a 31-127 ft (9.45-38.72 m) five-section boom. This model can be equipped with a 31 ft (9.45 m) jib, offering a vertical reach of 166 ft (50.60 m) or a 31-55 ft (9.45-16.76 m) jib providing a vertical reach of 190 ft (57.91 m).

31-127 ft (9.45-38.72 m) five-section hydraulic boom



31-127 ft (9.45-38.72 m) five-section hydraulic boom



18FJ31 31 ft (9.45 m) single-section manual jib

31-127 ft (9.45-38.72 m) five-section hydraulic boom



18FJ55 31-55 ft (9.45-16.76 m) two-section manual jib

Model 18142 — Equipped with a 34-142 ft (10.36-43.29 m) five-section boom. This model can be equipped with a 26 ft (7.92 m) single-section manual jib, offering a vertical reach of 176 ft (53.64 m).

34-142 ft (10.36-43.29 m) five-section hydraulic boom



34-142 ft (10.36-43.29 m) five-section hydraulic boom











18FJ26 26 ft (7.92 m) single-section manual jib

Note: maximum tip height is measured with outriggers/stabilizers fully extended.

5

1800 Winch Data

			1 Part Line	2 Part Line	3 Part Line	4 Part Line	5 Part Line	6 Part Line	7 Part Line	8 Part Line
										
Maximum boom length at maximum elevation with rigging shown to reach the ground			168 ft (48.16 m) with 31 ft. (9.45 m) jib	114 ft (34.75 m)	83 ft (25.30 m)	64 ft (19.51 m)	52 ft (15.85 m)	43 ft (13.11 m)	36 ft (10.97 m)	31 ft (9.45 m)
Standard Planetary Winch	Cable Supplied	Average Breaking Strength	Lift and Speed	Lift and Speed	Lift and Speed	Lift and Speed	Lift and Speed	Lift and Speed	Lift and Speed	Lift and Speed
Low Speed	5/8" Diameter Rotation Resistant IWRC	\$6,400 lb (25 583 kg)	10,000 lb (4536 kg) 205 fpm (62 m/min)	20,000 lb (9072 kg) 103 fpm (31 m/min)	30,000 lb (13 608 kg) 68 fpm (21 m/min)	40,000 lb (18 144 kg) 51 fpm (16 m/min)	50,000 lb (22 680 kg) 41 fpm (13 m/min)	60,000 lb (27 216 kg) 34 fpm (10 m/min)	70,000 lb (31 751 kg) 29 fpm (9 m/min)	80,000 lb (36 287 kg) 26 fpm (8 m/min)
High Speed	5/8" Diameter Rotation Resistant IWRC	\$6,400 lb (25 583 kg)	5,000 lb (2268 kg) 110 fpm (125 m/min)	10,000 lb (4536 kg) 205 fpm (62 m/min)	15,000 lb (6804 kg) 137 fpm (42 m/min)	20,000 lb (9072 kg) 103 fpm (31 m/min)	25,000 lb (11 340 kg) 82 fpm (25 m/min)	30,000 lb (13 608 kg) 68 fpm (21 m/min)	35,000 lb (15 876 kg) 59 fpm (18 m/min)	40,000 lb (18 144 kg) 51 fpm (16 m/min)

Winch	Full Drum Pull	Allowable Cable Pull
Standard Planetary	5,000 lb (2268 kg)	High Speed 11,280 lb (5117 kg)
Auxiliary Planetary	10,000 lb (4536 kg)	Low Speed 11,280 lb (5117 kg)

- All winch pulls and speeds in this chart are shown on the fifth layer
 - Winch line pulls would increase on the first, second, third and fourth layers
 - Winch line speed would decrease on the first, second, third and fourth layers
 - Winch line pulls may be limited by the winch capacity or the ANSI 5 to 1 cable safety factor
 - Hook blocks are rated at maximum capacity for the block.
- Do not exceed rated cable pull with any block.

Block Type	Rating	Weight
Aux. Boom Head		100 lb (45.36 kg)
Downhaul Weight	5 ton (4.54 t)	180 lb (81.65 kg)
1 Sheave Block	15 ton (13.61 t)	375 lb (170.10 kg)
2 Sheave Block	25 ton (22.68 t)	640 lb (290.30 kg)
3 Sheave Block	35 ton (31.75 t)	870 lb (394.63 kg)
4 Sheave Block	40 ton (36.29 t)	970 lb (439.98 kg)

Accessories

Radio Remote Controls - Joystick-controlled radio remotes with multi functioning. Eliminates the handling and maintenance concerns that accompany cabled remotes. Operate to a range of about 250 feet (76 m), varying with conditions.

One-Person Basket - Strong but lightweight steel basket with 300-lb. (139-kg) capacity, gravity hung with swing lock and full body harness.

Heavy-duty Personnel Basket - 1,200-lb. (544-kg) capacity steel basket with four safety loops. Gravity leveling 72- x 42-inch (183- x 107-cm) platform. Fast attachment and secure locking systems. Load chart must show at least 3,550 lb (1610 kg) minimum to operate this accessory on main boom; 2,150 lb (975 kg) on jib.

Winch Option - Auxiliary winch, 10,000-lb (4535.92-kg) line pull with 375 ft (114.30 m) of extremely stable and flexible 5/8-in diameter rotation-resistant wire rope and 180-lb (81.65-kg) downhaul weight.

Air Conditioning - Air conditioning for the operator's cab.

Safety Beacon - Amber safety beacon for cab roof.

Spotlight - Manually adjusted from crane cab.

Worklight Wiring on Boom - Provision for switch and wiring for a customer-supplied worklight on boom.

Fixed Position Worklight - Fixed-position worklight on the cab with in-cab control.

Remote Worklight - Remotely operated worklight with an in-the-cab control.

Winch Motion Indicator - Winch drum rotation indicator(s) are available.

"Light Bar" Indicator - Available for exterior use. Displays LMI status: Green = OK; Yellow = Prewarn; Red = Overload.

Fenders - Bright aluminum fenders in lieu of standard fenders only.

Tool Boxes - Tool boxes available with any fenders offered.

Manual Rotation Lock - Positive lock (360° positioning) to prevent swing of turret/boom.

- Model NB3R (lift, turn, telescope)
- Model NB4R (adds winch control)

- Model B1-S
- Model 2B1-S (for dual locking baskets)

- Model BSA-1
- Model BSA-R1 (provides rotation)

- Model 18AW

- Model AC

- Model ABR

- Model MS

- Model WLB

- Model WLF

- Model WLR

- Model WDRI

- Model LBI/LBE

- Model AFPA, AFTA

- Model TB

- Model MRL

Dimensions Specifications:

All dimensions are in inches (mm) unless otherwise specified.

SERIES	RETRACTED LENGTH	EXTENDED LENGTH	G	WEIGHT WITH OIL *
18103	31 ft (9.45 m)	103 ft (31.40 m)	69 in (1.75 m)	33,850 lb (15,354 kg)
18127	31 ft (9.45 m)	127 ft (38.72 m)	69 in (1.75 m)	35,275 lb (16,000 kg)
18142	34 ft (10.36 m)	142 ft (43.28 m)	87 in (2.21 m)	36,970 lb (16,769 kg)
1879	31 ft (9.45 m)	79 ft (24.08 m)	69 in (1.75 m)	31,815 lb (14,431 kg)

* WEIGHT INCLUDES ALL ITEMS INCLUDING COMPLETE HO OUTRIGGERS, 2300 lb COUNTERWEIGHT, 375-lb BLOCK, DECKS AND SFO. BOOMS FULLY RETRACTED.

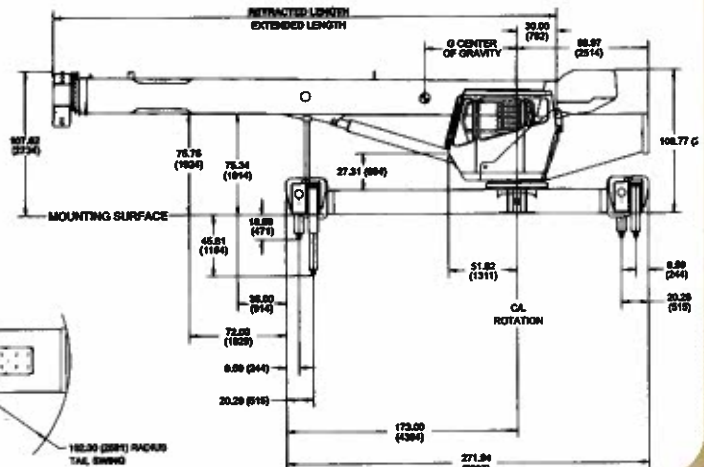
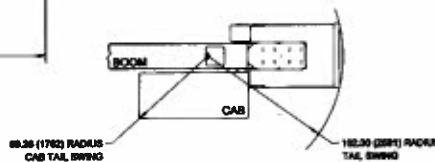
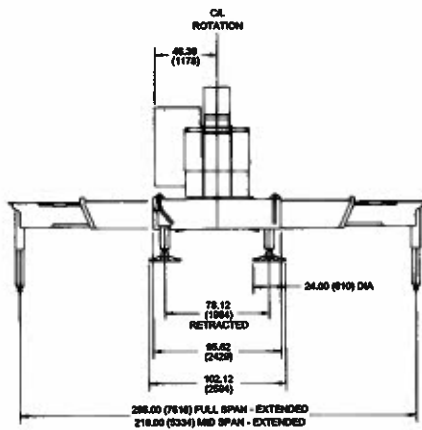

Your National Dealer:

National Crane is ISO 9001 Certified

General Offices:
11200 North 148th Street
Waverly, NE 68462 USA
Phone: (402) 786-6300
FAX: (402) 786-6363
Email: sales@nationalcrane.com
Web: www.nationalcrane.com

National Crane reserves the right to change designs, prices and specifications at any time without notice.
Printed in U.S.A. Form No. 1800/0303/BA/MWP