

# Series 1400: National Telescoping Crane

America's Leading Manufacturer of Truck-Mounted Hydraulic Cranes.

1400

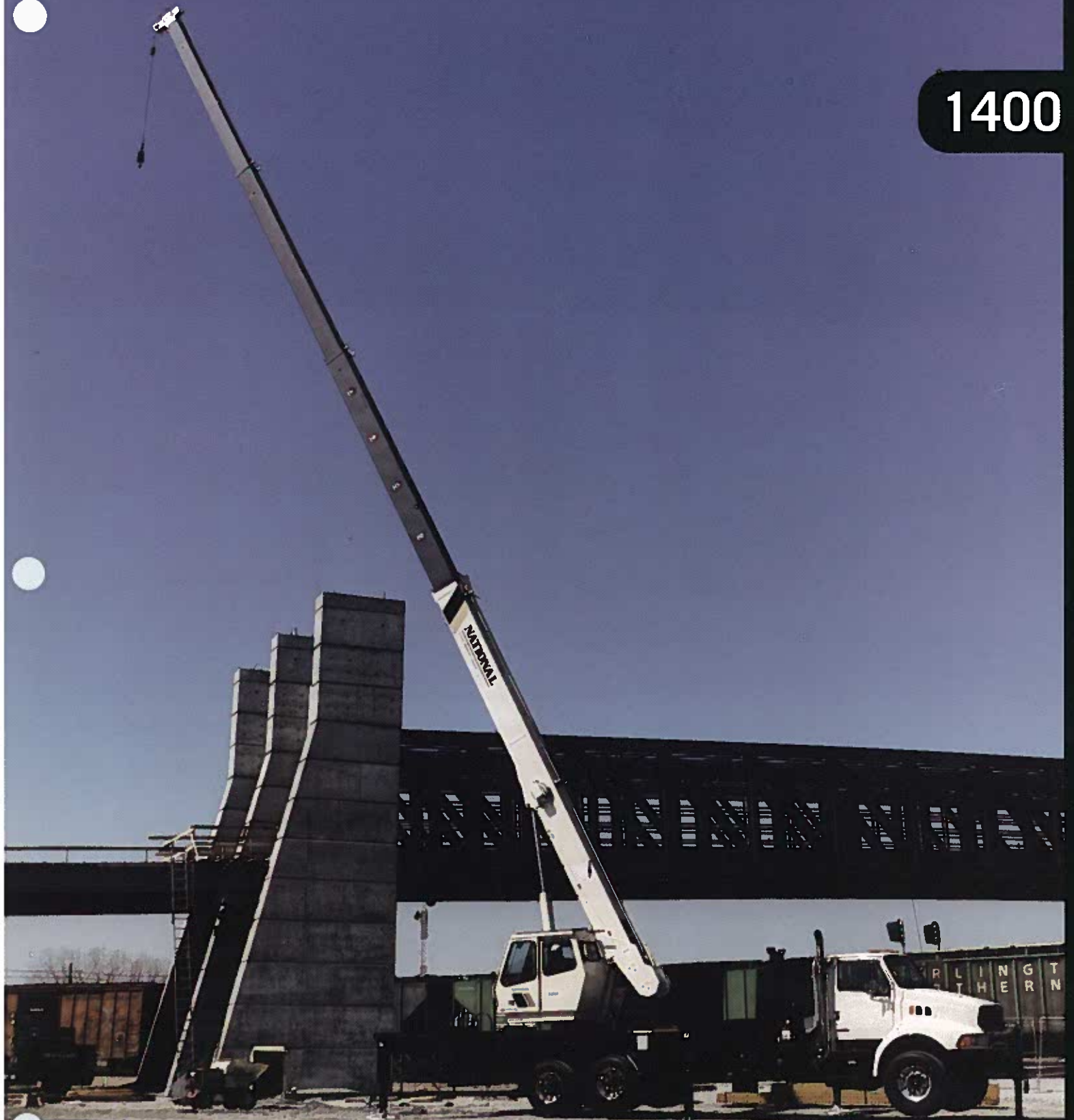

Photos may show optional equipment.

**NATIONAL  
CRANE**

## Why Buy a National Series 1400?



- **33-ton Rating** – The new 1400 is a 33-ton machine, a 10% increase in capacity over the Series 1300.
- **New 127-foot Five-section Boom** – The longest in its size range. The longer boom allows the operator to perform more lifts without the use of a jib, reducing setup time and improving efficiency. A 100-foot four-section boom or a 110-foot four-section boom is also available.
- **Overload Protection** – All National cranes are equipped with overload protection:
  - Load Moment Indicator (LMI) standard on all series 1400 machines.
  - LMI display and CPU are weatherproof.
  - LCD display is visible in full or low light.
  - All crane load lifting values are displayed simultaneously.
- **Self-lubricating "Easy glide" Boom Wear Pads** – The self-lubricating boom pads, standard on the 1400, reduce the conditions that cause boom chatter and vibration. The net result is smoother crane operation.
- **Internal Anti-two-block Wire** – This exclusive design, standard on the Series 1400, routes the wiring through the inside of the boom. No more snagging the wire on obstructions.
- **"H"-style Outriggers** – Two sets of "H"-style outriggers with 24' 6" (7.47 m) span, with removable ball and socket aluminum foot pads. Independent controls located on each side of the crane - can be positioned at mid-span setting of 17' (5.18 m).
- **Continuous Rotation/Glide Swing** – The series 1400 is supplied with continuous rotation standard, along with the "glide swing" feature - allowing free swing during rotation - and a manually applied foot brake. 375° non-continuous rotation is also available.
- **Adjustable Swing Speed** – Standard on the 1400. A control knob located on the swing motor brake release valve can be easily adjusted to the crane operator's swing speed preference.
- **Oil Cooler** – Radiator mounted at boom rest with electric fan is standard, with an option to deduct the cooler for low duty-cycle applications.
- **Heavier Duty Torsion Box** – The stronger standard torsion box improves rigidity, reduces truck frame flex and reduces the need for counterweight.
- **Speedy-reeve Boom Tip and Sheave Blocks** – These standard features simplify rigging changes by decreasing the time needed to change line reeving.
- **Pre-painted Components** – Painting crane components before assembly reduces the possibility of rust, improves serviceability and enhances the appearance of the machine.
- **Deluxe Operator's Cab** – Rigid galvanized steel structure, well insulated, with ample safety glass for operator visibility and comfort. Multi-position seat with arm rest controls, ventilation fans, propane heater, wipers. Optional air-conditioning is available. Optional open-seat control station in lieu of enclosed cab is available.
- **Improved Serviceability** –
  - Bearings on the boom extend and retract cables can be greased through access holes in the boom side plates.
  - Number of internal boom parts has been reduced, decreasing service time when rebuilding the machine.
- **New State-of-the-art Control Valve** – Provides smoother operation. The new design eliminates parts, reducing repair costs and improving the machine's serviceability.
- **National Crane Is the Market Leader** – National is number one in the production of commercial truck-mounted boom trucks. National has the resources, programs and people to provide our customers with reliable products.
- **National has the boom truck industry's leading test program.** The Series 1400 is a completely new design that has been through a strenuous six-month testing regimen. Structural parts of the crane have been cycle tested up to 60,000 cycles at full capacity. In addition to cycle testing, each model has been subjected to state-of-the-art strain gauge testing that measures metal deformation as small as one one-millionth of an inch. The net result is that any weak areas are caught in test, not on job sites where costly downtime occurs.
- Outrigger, lift and telescoping cylinders are manufactured by National Crane, so that the seals, packing glands, and other cylinder components are traced for accurate shipment of replacement parts.
- Parts are available for all National Crane machines, even if they are 35 years old.
- National has a formalized quality program and is ISO 9001 approved.
- **You Expect National Crane to be a Quality Product That Will Provide Years of Service, and So Do We.**

- 33-ton (29.94-t) maximum capacity

- 171ft (52.12-m) maximum vertical reach\*

- 135-ft (41.15-m) maximum vertical hydraulic reach\*

- Load Moment Indicator system (LMI)

- Proportional boom extension

- High performance planetary winch

- Heavy-duty triple pump hydraulics

- 99 Gallon(375L) hydraulic reservoir with 10 micron return filter.

\* Maximum vertical reach is ground-level to boom tip height at maximum extension and angle with outriggers/stabilizers fully extended.

# 1400 Capacities



## Load Rating Chart: Model 14110 with 54-ft jib

Series 1400 Load Rating Charts are available for all Model 14100, 14110, and 14127 cranes. National will send you a chart by FAX or mail on request - or you may secure needed load rating information through your nearest National dealer.

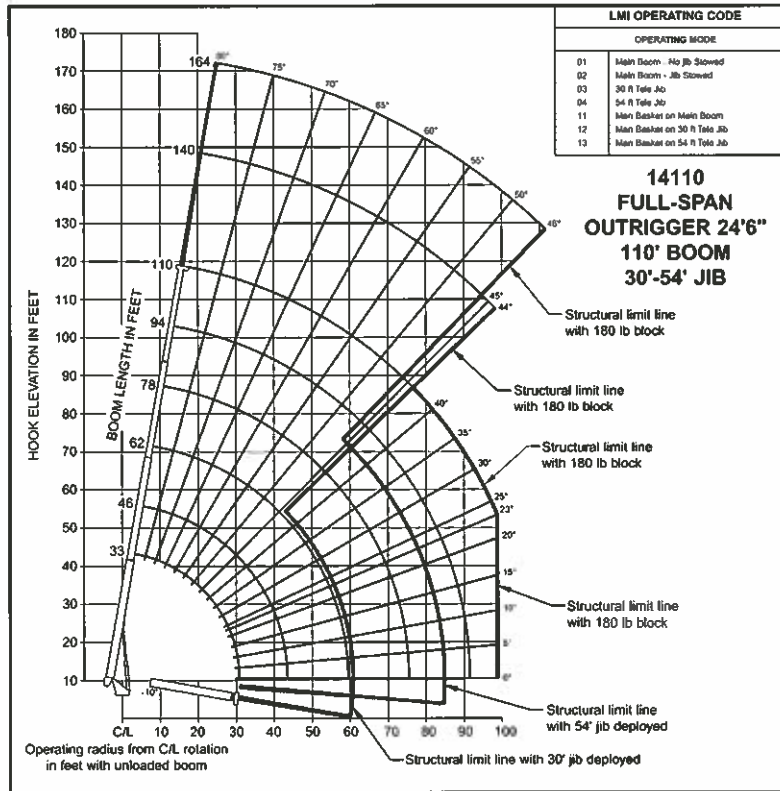

### Caution:

- Do not operate crane booms, jib extensions, any accessories or loads within 10 ft (3m) of live power lines or other conductors of electricity
- Jib and boom capacities shown are maximum for each section
- Do not exceed jib-capacities at reduced radii
- Load ratings shown on the appropriate charts are maximum allowable loads with the crane mounted on a factory-approved truck and all outriggers at either full span or at mid span range and set on a firm level surface so that the crane is level and all tires are suspended.
- Always level the crane with the level indicator located on the crane
- The operator must reduce loads to allow for factors such as wind, ground conditions, operating speeds and their effects on freely suspended loads
- Overloading this crane may cause structural collapse or instability
- Weights of any accessories attached to the boom or loadline must be deducted from the load chart capacities
- Do not deadhead lineblock against boom tip when extending boom or winching up
- Keep at least three wraps of loadline on drum at all times
- Use only specified cable with this machine

## LOAD RATINGS

Load Radius (Feet)	Loaded Boom Angle	33 Ft. Boom (Lb)	Loaded Boom Angle	A 46 Ft. Boom (Lb)	Loaded Boom Angle	B 62 Ft. Boom (Lb)	Loaded Boom Angle	C 78 Ft. Boom (Lb)	Loaded Boom Angle	D 94 Ft. Boom (Lb)	Loaded Boom Angle	110 Ft. Boom (Lb)	
6	76.7	66,000											
8	72.8	51,700											
10	68.9	42,200	76	37,000									
12	64.9	38,400	73.4	33,400	78.2	26,900							
15	58.6	32,200	69.3	28,000	75.6	24,900	79.4	22,800					
20	48.5	23,900	62.2	21,650	70.2	19,300	74.8	17,900	78.2	14,100			
25	33.3	17,600	54.4	17,800	64.9	16,050	71	14,550	75.1	12,400	77.4	9,200	
30			46.2	15,100	59.8	13,600	67	12,300	71.9	11,200	75.1	8,700	
35			36.3	12,750	54	12,050	63	10,600	68.5	9,750	72.5	8,000	
40			22.9	10,100	47.8	10,450	58.7	9,300	65.5	8,550	69.6	7,200	
45					41.6	8,750	54.5	7,800	61.9	7,350	67	6,400	
50					33.9	7,200	49.7	6,900	58.2	6,250	63.9	5,700	
55					23.6	5,600	44.5	6,000	54.4	5,500	60.8	4,700	
60								38.6	4,900	50.5	4,800	57.6	4,000
65								31.9	4,000	46.3	4,200	54.4	3,400
70								23.3	3,250	41.7	3,450	51	2,700
75								8.7	2,500	36.6	2,750	47.4	2,300
80										30.7	2,250	43.6	1,800
85										23.5	1,750	39.3	1,200
90										12.5	1,250	34.7	1,000
95												29.6	800
100												23.3	600
	0	12,000	0	7,500	0	4,500	0	2,100	0	1,000			

\* Shaded areas are structurally limited capacities.

Load Radius (ft)	Loaded Boom Angle	30-ft Jib (lb)	Loaded Boom Angle	54-ft Jib (lb)
30	79.1	5,050		
35	77.4	5,000	79.5	2,650
40	75.6	4,950	78.1	2,600
45	74.7	4,700	77.6	2,500
50	71.6	4,300	75	2,400
55	69.5	4,000	73.2	2,300
60	67.3	3,700	71.4	2,200
65	65.1	3,400	69.6	2,100
70	62.9	3,150	67.8	2,000
75	60.5	2,850	66	1,850
80	58	2,500	64.1	1,750
85	55.5	2,000	62.2	1,600
90	52.8	1,600	60.2	1,500
95	50	1,200	58	1,400
100	47.1	850	55.8	1,300
105	43.9	500	53.6	1,200
110			51.2	1,000
115			48.7	750
120			46.1	500

RATED LOAD REDUCTIONS WITH JIBS		
Boom Length	30'-54' JIB STOWED	30'-54' JIB ERRECTED AT 30' LENGTH
33'	Reduce load 850 lb	Reduce load 2,200 lb
46'	Reduce load 600 lb	Reduce load 1,950 lb
62'	Reduce load 450 lb	Reduce load 1,850 lb
76'	Reduce load 350 lb	Reduce load 1,800 lb
94'	Reduce load 300 lb	Reduce load 1,750 lb
110'	Reduce load 250 lb	Reduce load 1,700 lb

# Mounting Configurations

The mounting configuration shown is based on the Series 1400 with an 85% stability factor. The complete unit must be installed in accordance with factory requirements and a test performed to determine actual stability and counterweight requirements since individual truck chassis vary. If bare truck weights are not met, counterweight will be required. The front bumper stabilizer (SFO) is required for all installations. Chassis must be equipped with a front frame suitable for SFO addition. Contact factory for complete chassis specifications.

Working area . . . . .	360°
Gross Axle Weight Rating Front . . . . .	20,000 lb (9072 kg)*
Gross Axle Weight Rating Rear . . . . .	34,000 lb (15 422 kg)*
Gross Vehicle Weight Rating . . . . .	54,000 lb (24 494 kg)*
Wheelbase . . . . .	Minimum 258 in (655 cm)
Cab to Axle/trunnion (CA/CT) . . . . .	Minimum 180 in (457 cm)
After Frame (AF) . . . . .	92 in (234 cm) minimum
Frame Section Modulus (SM), front axle to end of afterframe, w/110,000 PSI (758 MPa) . . . . .	30 in <sup>3</sup> (492 cm <sup>3</sup> )
Stability Weight, Front . . . . .	9,000 lb (4082 kg) minimum**
Stability Weight, Rear . . . . .	8,000 lb (3629 kg) minimum**
Estimated Average Final Weight . . . . .	51,880 lb (23 585 kg)***

The diagram shows the 360° working area that can be achieved with the front stabilizer (standard on the Series 1400). The front stabilizer is required when extending the boom and lifting loads forward of the outriggers. A minimum of 10-in (164 cm<sup>3</sup>) section modulus at 110,000 psi (759 MPa) is required from the rear of the front spring hanger forward to the front stabilizer. Integral front frame extension recommended.

\* Required to mount basic crane with 30-ft (9.15-m) jib option. Additional options or heavier bare chassis weights will require additional axles or a GVWR in excess of 54,000 lb (24 494 kg); in some states, special permits for overload are required.

\*\* Estimated axle scale weights prior to installation of crane, stabilizers and subbase for 85% stability.

\*\*\* Includes basic crane without jib, 100-gal (379-L) fuel tank and two workers (300 lb, 136kg) in cab.

**Note: Chassis preferred with extended front frame rails for SFO addition.**

## TRUCK REQUIREMENTS

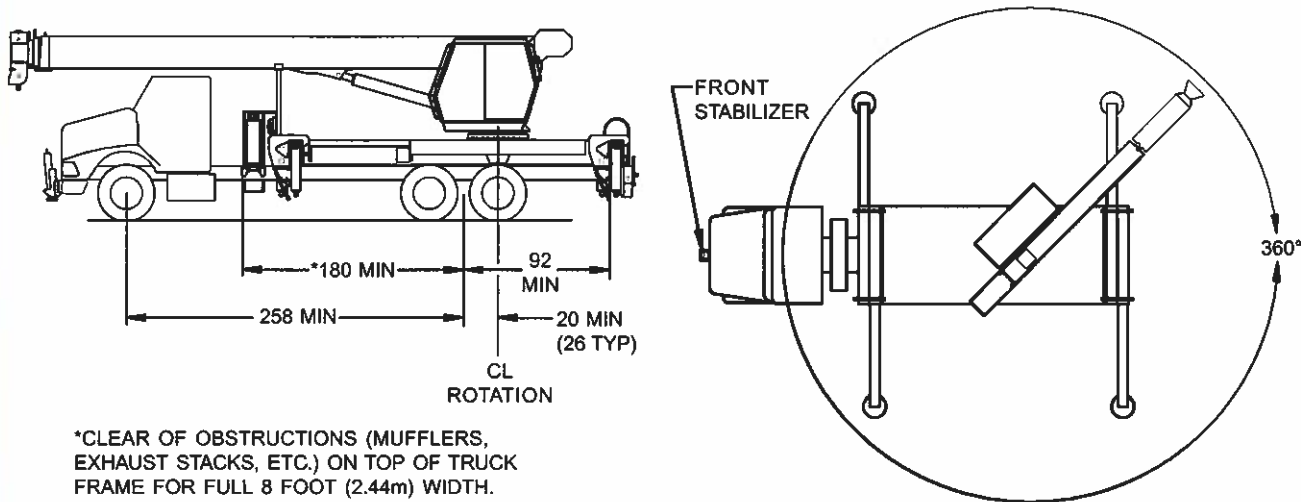

\*CLEAR OF OBSTRUCTIONS (MUFFLERS, EXHAUST STACKS, ETC.) ON TOP OF TRUCK FRAME FOR FULL 8 FOOT (2.44m) WIDTH.

### Notes:

- Gross Vehicle Weight Rating (GVWR) is dependent on all components of the vehicle (axles, tires, springs, frame, etc.) meeting manufacturers' recommendations; always specify GVWR when purchasing trucks.
- Diesel engines require a variable speed governor and energize-to-run fuel solenoid for smooth crane operation. Electronic fuel-injected engines are required.

- All mounting data is based on a National Series 1400 with the standard subbase and an 85 percent stability factor.
- The complete unit must be installed in accordance with factory requirements, and a test performed to determine actual stability and counterweight requirements per SAE J765; contact the factory for details.
- Transmission neutral safety interlock switch is required.

# Boom and Jib Combinations Data

Available in three basic models.

**Model 14100** — Equipped with a 30 ft 10 in to 100 ft (9.40-30.49 m) four-section boom. This model can be equipped with a 30 ft (9.15 m) single-section jib or a 30-54 ft (9.15-16.46 m) two-section jib. Maximum tip height w/30ft (9.15 m) jib is 137 ft (41.77 m), while maximum tip height w/30-54 ft (9.15-16.46 m) jib is 161 ft (49.08 m).

30'10" - 100' (9.40-30.49 m) four-section boom



30'10" - 100' (9.40-30.49 m) four-section boom      **14FJ30M**      30 ft (9.15 m) single-section jib



30'10" - 100' (9.40-30.49 m) four-section boom      **14FJ54M**      30-54 ft (9.15-16.46 m) two-section jib



**Model 14110** — Equipped with a 33 ft 4 in to 110 ft (10.16-33.53 m) four-section boom. This model can be equipped with a 30 ft (9.15 m) single section jib or a 30-54 ft (9.15-16.46 m) two-section jib. Maximum tip height w/30ft (9.15 m) jib is 147 ft (44.82 m), while maximum tip height w/54 ft (16.46 m) jib is 171 ft (52.13 m).

33'4" - 110' (10.16-33.53 m) four-section boom



33'4" - 110' (10.16-33.53 m) four-section boom      **14FJ30M**      30 ft (9.15 m) single-section jib



33'4" - 110' (10.16-33.53 m) four-section boom      **14FJ54M**      30-54 ft (9.15-16.46 m) two-section jib



**Model 14127** — Equipped with a 31 ft 7 in to 127 ft (9.63-38.72 m) five-section boom. This model can be equipped with a 30 ft (9.15 m) single-section jib. Maximum tip height w/ 30 ft (9.15 m) jib is 164 ft (50.00 m).

31'7" - 127' (9.63-38.72 m) five-section boom











31'7" - 127' (9.63-38.72 m) five-section boom      **14FJ30M**      30 ft (9.15 m) single-section jib



**Note:** maximum tip height is measured with outriggers/stabilizers fully extended.

## 1400 Winch Data

- Do not deadhead line block against boom tip when extending boom.
- Keep at least 3 wraps of loadline on drum at all times.
- Use only 5/8" diameter rotation-resistant cable with 45,400 pounds breaking strength on this machine.

			1 Part Line	2 Part Line	3 Part Line	4 Part Line	5 Part Line	6 Part Line	7 Part Line	8 Part Line
										
<b>MAXIMUM BOOM LENGTH AT MAXIMUM ELEVATION WITH RIGGING SHOWN WITH LOAD BLOCK AT GROUND LEVEL</b>			110' boom w/ 54" jib	110'	83'	64'	52'	43'	36'	31'
Winch	Cable Supplied	Average Breaking Strength	Lift and Speed	Lift and Speed	Lift and Speed	Lift and Speed	Lift and Speed	Lift and Speed	Lift and Speed	Lift and Speed
Standard Planetary Winch Low Speed	5/8" Diameter Rotation Resistant 18 x 19 IWRC	45,400 lb (20 593 kg)	9,000 lb (4082 kg) 170 fpm (52 m/min)	18,000 lb (8165 kg) 85 fpm (26 m/min)	27,000 lb (12 247 kg) 57 fpm (17 m/min)	36,000 lb (16 329 kg) 43 fpm (13 m/min)	45,000 lb (20 412 kg) 34 fpm (10 m/min)	54,000 lb (24 494 kg) 28 fpm (9 m/min)	63,000 lb (28 576 kg) 24 fpm (7 m/min)	66,000 lb (29 937 kg) 21 fpm (6 m/min)
Standard Planetary Winch High Speed	5/8" Diameter Rotation Resistant 18 x 19 IWRC	45,400 lb (20 593 kg)	4,400 lb (1996 kg) 340 fpm (104 m/min)	8,800 lb (3992 kg) 170 fpm (52 m/min)	13,200 lb (5987 kg) 113 fpm (34 m/min)	17,600 lb (7983 kg) 85 fpm (26 m/min)	22,000 lb (9979 kg) 68 fpm (21 m/min)	26,400 lb (11 975 kg) 57 fpm (17 m/min)	30,800 lb (13 971 kg) 49 fpm (15 m/min)	35,200 lb (15 967 kg) 43 fpm (13 m/min)

All winch pulls and speeds in this chart are shown on the fourth layer. Winch line pulls would increase on the first, second and third layers. Winch line speed would decrease on the first, second and third layers. Winch line pulls may be limited by the winch capacity or the ANSI 5 to 1 cable safety factor. These are shown below:

Winch	Full Drum Pull	Allowable Cable Pull
Standard planetary	4,400 lb. (1996 kg) (high speed) 9,000 lb. (4082 kg) (low speed)	9,080 lb. (4119 kg)

5 Ton	Aux. Boom Head	100 lb
15 Ton	Downhaul Weight	180 lb
25 Ton	1 Sheave Block	375 lb
35 Ton	2 Sheave Block	640 lb
36 Ton	3 Sheave Block	870 lb
	4 Sheave Block	970 lb

# Accessories

**Open Swing Seat** - Open swing seat controls in lieu of standard cab with heater.

• **Model SSC**

**Auxiliary Winch** - 9,000-lb line pull with 375 ft of 5/8-in diameter rotation-resistant wire rope and 180-lb downhaul weight.

• **Model 14AW**

**Winch Drum Rotation Indicator** - Available for single or dual winches.

• **Model WDRI**

**Radio Remote Controls** - Eliminate the handling and maintenance concerns that accompany cabled remotes. Operate to a range of about 250 feet (76 m), varying with conditions.

• **Model NB3R** (lift, turn, telescope)  
• **Model NB4R** (adds winch control)

**One-Person Basket** - Strong but lightweight steel basket with 300-lb. (136-kg) capacity, gravity hung with swing lock and full body harness.

• **Model B1-S**  
• **Model 2B1-S** (for dual locking baskets)

**Heavy-duty Personnel Basket** - 1,200-lb. (544-kg) capacity on boom (500 lb on jib) steel basket with four safety loops. Gravity leveling 72- x 42-inch (183- x 107-cm) platform. Fast attachment and secure locking systems. Load chart must show at least 3,550 lb (1610 kg) minimum to operate this accessory on main boom; 2,150 lb (975 kg) on jib.

• **Model BSA-1**  
• **Model BSA-R1** (provides rotation)

**Pallet Fork** - Manual leveling fork with adjustable throat and teeth, 4,400-lb. (1996-kg) capacity.

• **Model MKF**

**Loose Material Clam** - Moves up to 2/3 yard<sup>3</sup> (.50 m<sup>3</sup>) material. Bucket hooks easily to loadline and includes manual control hose reel.

• **Model LMC**

**Air Conditioning** - Hydraulically driven air conditioning compressor with in-cab cool air outlets. External condenser on side of turret. Requires 130+ amp chassis alternator.

• **Model AC**

**Aluminum Fender Group** - Available in lieu of standard steel flatbed for weight savings.

• **Model AFG**

## Dimensions Specifications:

All dimensions are in inches (mm) unless otherwise specified.

\*Weight includes all items including complete HO outriggers, 180 lb (82 kg) downhaul weight, reservoir, decks, ladders and SFO. Booms fully retracted.

Series	G inches (cm)	With Oil/Wt* lb (kg)
14100	81 (206)	33,650 (15 263)
14100	88 (224)	34,550 (15 672)
14127	88 (218)	35,820 (16 248)

NOTES:  
DIMENSIONS ARE INCHES (MM)  
UNLESS OTHERWISE SPECIFIED.

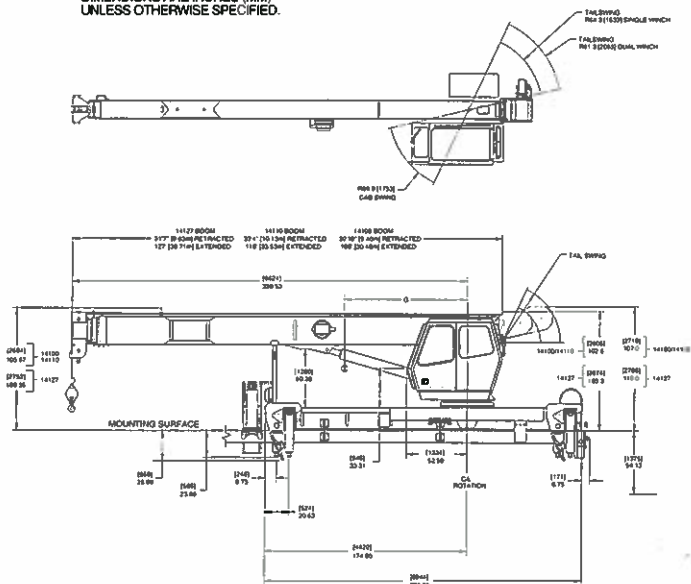
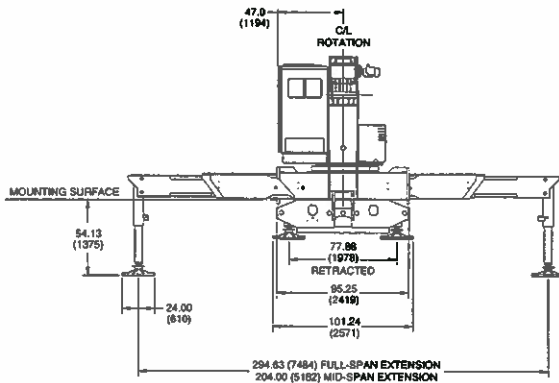

### General Offices:

11200 North 148th Street

Waverly, NE 68462 USA

Phone: (402) 786-6300

FAX: (402) 786-6363

Email: sales@nationalcrane.com

Web: www.nationalcrane.com

Your National Dealer:

National  
Crane is  
ISO 9001  
Certified

National Crane reserves the right to change designs, prices and specifications at any time without notice.

Printed in U.S.A. Form No. 1400/1100/5M/AA/JN